



ELECTRIC

RANGE COOKERS

160 YEARS OF HOME COOKING

ELECTRIC RANGE COOKERS

Radiant heat with added cooking control

1000 T

Page 4



985mm

600 T

Page 5



595mm

Our electric range cookers feature independently controlled temperature settings and ESSE's power share system optimises performance to ensure all the elements work together in harmony whether a single hotplate or the whole cooker is in use.

The slumber mode oven and hotplate temperature pre-sets maintain economical power usage, shortening heat-up times prior to cooking and our 1000 models include a programmable timer for the ultimate in efficiency and control.

The high thermal mass of ESSE electric ovens provides a stable temperature and the oven surfaces are heated by our unique patented surround element technology.

This means temperatures are consistent throughout the space, so there's no need to turn dishes during cooking and they can even be placed directly on the base of the oven to cook.

Use the cast iron hotplate for boiling and frying, lower the temperature for simmering and griddling direct on the hob and when you need hot water in a hurry, the induction zone brings a panful to the boil almost instantly.

With no flue required an ESSE electric range cooker can be positioned in a location of your choice with standard power sockets.

And while you're preparing a meal your ESSE is also ensuring the kitchen remains warm and welcoming at all times.

1000 X

Page 6



985mm

600 X

Page 7

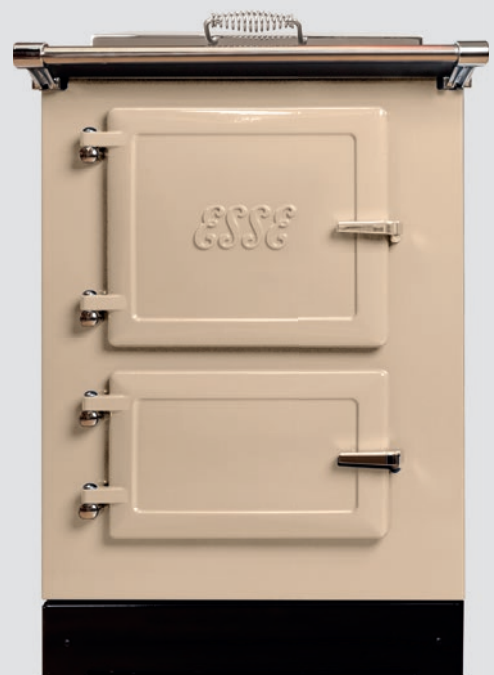

595mm

1000 T

ELECTRIC RANGE COOKER



ESSE's 1000 T range cooker is the traditional kitchen star – whatever the recipe and however many guests.

The 1000 T incorporates two independently controlled ovens, a full-width integrated grill in the top right oven, a temperature-set slow cooking oven and an induction hob alongside a cast iron hotplate and – with no flue required – this clever cooker will fit anywhere.

A programmable timer with countdown and temperature presets takes care of everything from the perfect soft-boiled egg for breakfast to cooking the Sunday roast.

The lower left oven is ideal for warming the plates for dinner or leaving a dish overnight for that delicious slow-cooked succulence.

Independent steam vents on top of the cooker allow humid ovens for baking and steaming and, when opened, allow that steam to escape for perfectly crisp roast potatoes.

- 1 Induction zone
- 2 Cast iron hob
- 3 Control panel
- 4 42ltr electric oven and full-width grill
- 5 Slow cook oven
- 6 30ltr electric oven
- 7 Runs on 2 x 13AMP sockets



Independent oven control

ESSE'S UNIQUE SURROUND HEAT CREATES

A MORE EVEN TEMPERATURE



PRODUCING

EVEN BETTER COOKING

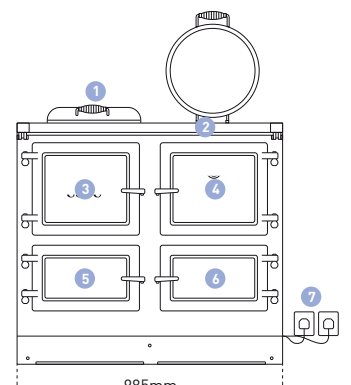

600 T

ELECTRIC RANGE COOKER



A compact electric range cooker that fits comfortably in any size kitchen.

Comprising separate top and bottom ovens, a full-width grill and a generous cast iron hotplate accommodating multiple pans, the 600 T delivers the plug in and cook flexibility of a modern cooker with all the style and elegance of an ESSE.

The 600 T slots easily into the space reserved for a standard cooker, providing the beauty of a cast iron stove with the amazing roasting and baking qualities of an ESSE range.



The dials for ovens, grill and hob are neatly housed in a stand alone external control panel which can be free standing or wall-mounted.

- 1 Control panel
- 2 Cast iron hotplate
- 3 42ltr electric oven and full-width grill
- 4 30ltr electric oven
- 5 runs on 1 x 13AMP socket

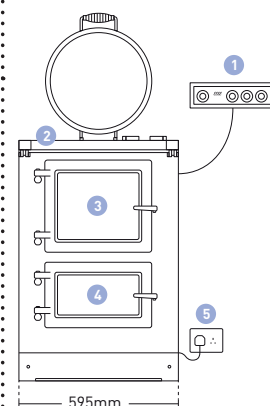

UNRIVALLED
COOKING QUALITIES
IN A
COMPACT
RANGE

INDEPENDENT, ADJUSTABLE
STEAM VENTS
FOR EACH OVEN

VOLUMINOUS
OVENS
DESIGNED FOR DEPTH
RATHER THAN WIDTH
TO
RETAIN HEAT

1000 X

ELECTRIC RANGE COOKER



This electric range cooker features the same independent ovens and grill with concealed control panel as the popular 1000 T yet gives owners a little e'X'tra capacity for entertaining.

With double the hob space, the contemporary 1000 X provides additional room for creative cooking and simple three pot wonders.

The three induction zone with cast iron plate combination and striking large lids are designed with the committed cook in mind.

The heat-conserving rectangular lids are beautifully engineered for easy lifting and

feature an elegant recessed drop hinge a feature first used on ESSEs in the 1950s. When the cooker is in use the lids double up as a splashback.

From melt-in-the-mouth meringues and slow-cooked stews to deliciously crispy roast potatoes or a full English breakfast for 12, the 1000 X is a true all-rounder; a modern classic that's ready to plug in and go to work in any setting.

**TAKES
MINUTES**

**TO HEAT UP
(NOT HOURS!)**

ESSE'S ENERGY EFFICIENT

**POWER
SHARE**

ENGINEERING

**GIVES YOU POWER WHERE
YOU NEED IT MOST AT ANY
ONE TIME**

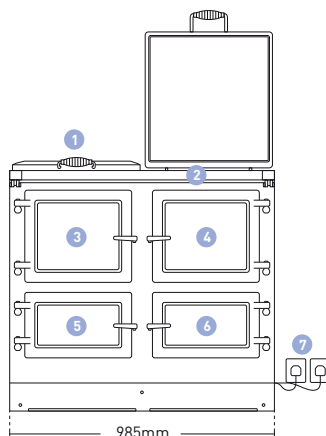

- 1 Three-zone induction hotplate
- 2 Large cooking plate with centre round cast iron plate
- 3 Control panel
- 4 42ltr electric oven and full-width grill
- 5 Slow cook oven
- 6 30ltr electric oven
- 7 Runs on 2 x 13AMP sockets

600 X

ELECTRIC RANGE COOKER



A compact electric range cooker that fits comfortably in any size kitchen.

Comprising separate top and bottom ovens, a full-width grill and a generous cast iron hotplate accommodating multiple pans, the 600 X delivers the plug in and go flexibility of a modern cooker with all the style and background heat of an ESSE.

The 600 X slots easily into the space reserved for a standard cooker, providing the beauty of a cast iron stove with the amazing roasting and baking qualities of an ESSE range.

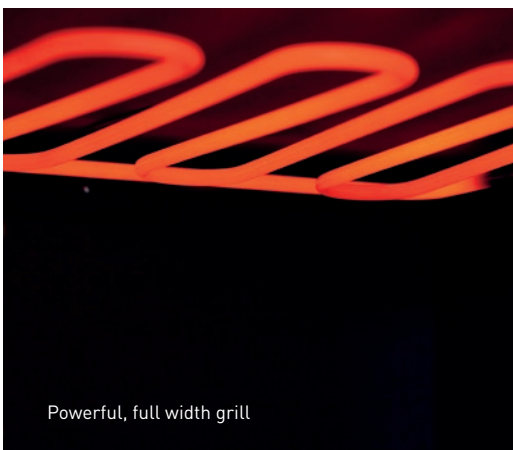

Powerful, full width grill



The dials for ovens, grill and hob are neatly housed in a stand alone external control panel which can be free standing or wall-mounted.

- 1 Control panel
- 2 Cast iron hotplate
- 3 42ltr electric oven and full-width grill
- 4 30ltr electric oven
- 5 runs on 1 x 13AMP socket

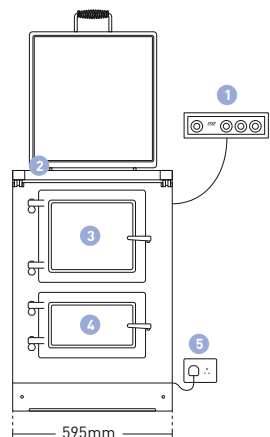

UNRIVALLED
COOKING QUALITIES
IN A
COMPACT
RANGE

NEW CENTRE
HOT(TER)PLATE
DESIGN

VOLUMINOUS
OVENS
DESIGNED FOR DEPTH
RATHER THAN WIDTH
TO
RETAIN HEAT



Black
(nearest RAL colour: 9005)



Cream
(nearest RAL colour: 1015)



Pepper
(nearest RAL colour: 2002)



Sage
(nearest RAL colour: 140 60 10)



Shadow
(nearest RAL colour: 5008)



White
(nearest RAL colour: 9003)

6

COLOURS AVAILABLE

.....
Indulge your inner interior designer

When you place an ESSE at the heart of your kitchen, choosing the ideal colour is key.

Strike the perfect tone from our choice of six of the best range cooker colours – ranging from the timeless Black and Cream to Sage and dramatic Pepper.

Since the early 1900s ESSE cookers have been available in hard wearing colour finishes skilfully applied by hand in our factory.

INCREASE CAPACITY

Match up a 600 with a 1000 to give more capacity.



600 T & 1000 T

Colour: Pepper

EXTRACTION HOODS

Compatible with flueless electric cookers, our hoods 'draw' the air through their easy-clean filters, neutralising unwanted odours and vapours.

With a choice of four settings, our hoods deliver a maximum extraction rate of 1000m³/hr. For maximum convenience, they can be operated manually or by using a 10 minute auto-programme.



NB: We are constantly developing and improving our products and we reserve the right to alter specifications without prior notice. COOK1121. Due to the limitations of the printing process, it is not possible to replicate cooker colours exactly as shown in our printed material. But trust us, they're better in person.

TECHNICAL SPECIFICATIONS

ELECTRIC MODEL TEST METHOD

In a controlled factory environment maintaining an average room temperature of 15°C the cooker is run at slumber for 1hr. All controls are turned up to full and within 1hr, full temperature on all cooking zones are reached. It is then run for a further 1hr, to simulate cooking.

The cooker is then returned to slumber for a remainder of 24hrs. Temperature measurements are taken every second and power readings taken at key points. Heat up to max + 1hr cooking = 5kW in 2hrs. The cooker runs at less than 2kW/hr once at max temp.

1000 T

Electricity supply	2 x 13AMP 220 - 240V
Weight	327kg
TOP OVEN CAPACITY	42 litres
W: 360mm H: 305mm D:460mm	
BOTTOM OVEN CAPACITY	30 litres
W: 360mm H: 205mm D:460mm	
Power consumption in slumber	0.4kW/hr
HEAT UP TIMES (from slumber)	
Top oven from 155°C to 240°C	15 mins
Bottom right oven from 70°C to 175°C	15 mins
Cast iron hotplate from 150°C to 350°C	30 mins
Cast Iron hotplate from 150°C to 200°C	7 mins
Induction	Instant
Compatible with extraction hood	

1000 X

Electricity supply	2 x 13AMP 220 - 240V
Weight	327kg
TOP OVEN CAPACITY	42 litres
W: 360mm H: 305mm D:460mm	
BOTTOM OVEN CAPACITY	30 litres
W: 360mm H: 205mm D:460mm	
Power consumption in slumber	0.5kW/hr
HEAT UP TIMES (from slumber)	
Top oven from 155°C to 240°C	15 mins
Bottom right oven from 70°C to 175°C	15 mins
Cast iron hotplate from 150°C to 350°C	30 mins
Cast Iron hotplate from 150°C to 200°C	7 mins
Three-zone Induction	Instant
Compatible with extraction hood	

600 T

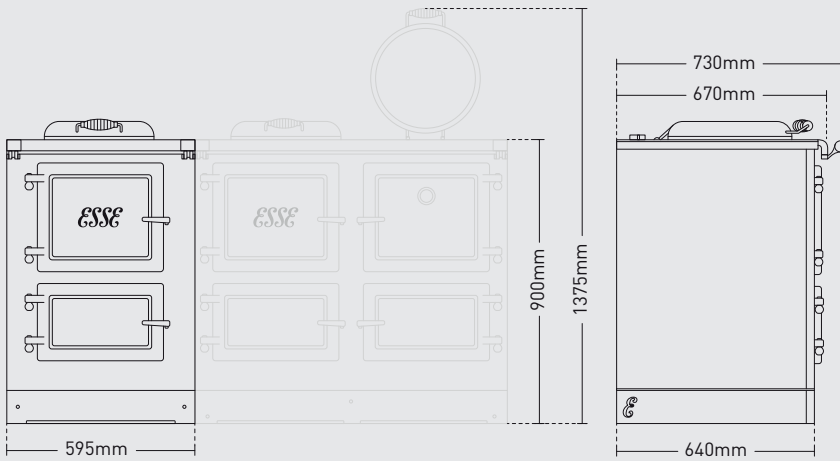

Electricity supply	1 x 13AMP 220 - 240V
Weight	200kg
TOP OVEN CAPACITY	42 litres
W: 360mm H: 305mm D:460mm	
BOTTOM OVEN CAPACITY	30 litres
W: 360mm H: 205mm D:460mm	
Power consumption in slumber	0.32kW/hr
HEAT UP TIMES (from slumber)	
Top oven from 155°C to 240°C	20 mins
Bottom oven from 70°C to 175°C	15 mins
Cast iron hotplate from 150°C to 350°C	30 mins
Cast Iron hotplate from 150°C to 200°C	7 mins

600 X

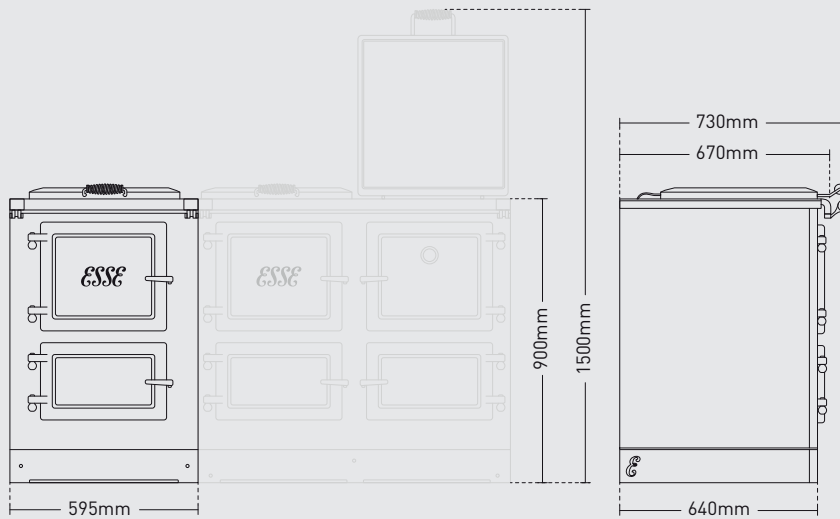

Electricity supply	1 x 13AMP 220 - 240V
Weight	200kg
TOP OVEN CAPACITY	42 litres
W: 360mm H: 305mm D:460mm	
BOTTOM OVEN CAPACITY	30 litres
W: 360mm H: 205mm D:460mm	
Power consumption in slumber	0.32kW/hr
HEAT UP TIMES (from slumber)	
Top oven from 155°C to 240°C	20 mins
Bottom oven from 70°C to 175°C	15 mins
Cast iron hotplate from 150°C to 350°C	30 mins
Cast Iron hotplate from 150°C to 200°C	7 mins

1600 T

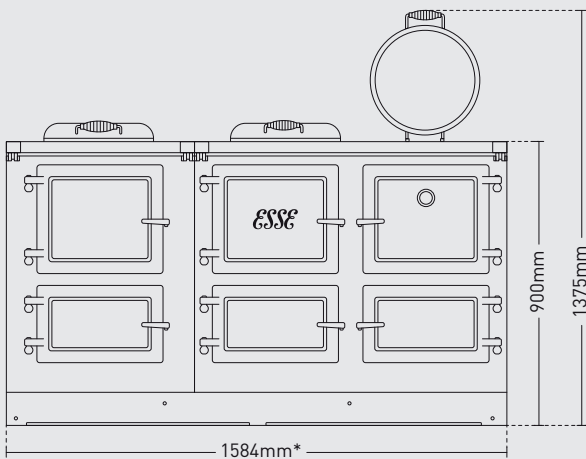

1600 X

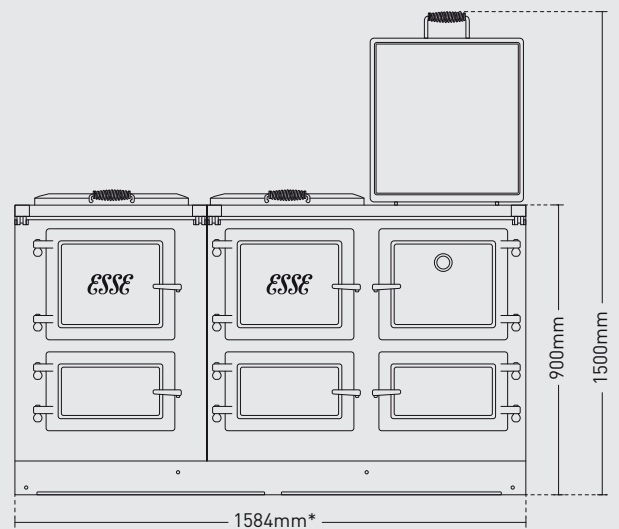

* Width includes a fitting tolerance

A CHOICE OF
LOOK

WHICH WILL YOU CHOOSE?



HOME DELIVERY OPTION



FACTORY TO KITCHEN

NEW CENTRE
HOT(TER)PLATE
DESIGN



INDEPENDENT, ADJUSTABLE
STEAM VENTS
FOR EACH OVEN



POWERFUL, FULL WIDTH
grill

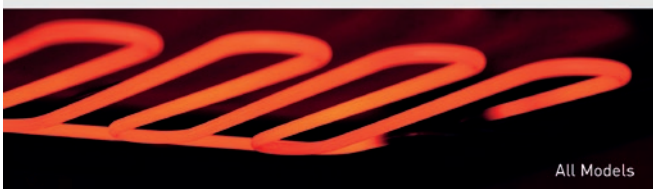

← TWO →
WIDTHS
1000MM AND 600MM



40% LARGER
HOTPLATE



PATENTED
**SURROUND
HEAT**
ON
ALL MODELS







SMILE!
IT'S
13AMP

Available in

6

Colours



-
- 1854** National hero and pioneer of modern nursing, FLORENCE NIGHTINGALE, was passionate about ESSE cookers and would use no other brand at her field hospital in Balaclava  during the CRIMEAN WAR.
- 1909** Explorer SIR ERNEST SHACKLETON relied upon an ESSE cooker to provide hot food and warmth to his shore party  during his British ANTARCTIC EXPEDITION. The ESSE 'Mrs Sam' stove still stands in Shackleton's base hut at Cape Royds.
- 1985** ESSE makes its big screen debut appearing alongside SIR ROGER MOORE as JAMES BOND in  'A View To Kill'.
- 2019** And today, ESSE stoves provide heat on HRH PRINCE CHARLES'S estate at Dumfries House in Ayrshire  and they are counted on to provide delicious food in Hugh Fearnley-Whittingstall's RIVER COTTAGE kitchens.
-

When Sir Ernest Shackleton set out to conquer the Antarctic, he needed a stove that would perform in the most hostile of conditions. He chose an ESSE. Just one story from ESSE's rich heritage.



SIR ERNEST SHACKLETON & HIS CREW

RANGE
COOKERS

Beautifully

**HAND-CRAFTED
IN  BRITAIN**



Contact us

Got a question for us here at ESSE?
Please do get in touch.

01282 813235
enquiries@esse.com
esse.com

ESSE

"ESSE" is a trade mark of ESSE Engineering Limited © 2021. All rights reserved.
Please don't reproduce any part of this publication without permission from ESSE Engineering Limited. Thank you.